

# askona

СПИТЕ, ЧТОБЫ ЖИТЬ

Инструкция  
по сборке стола туалетного  
Лама (Лама)  
200S001

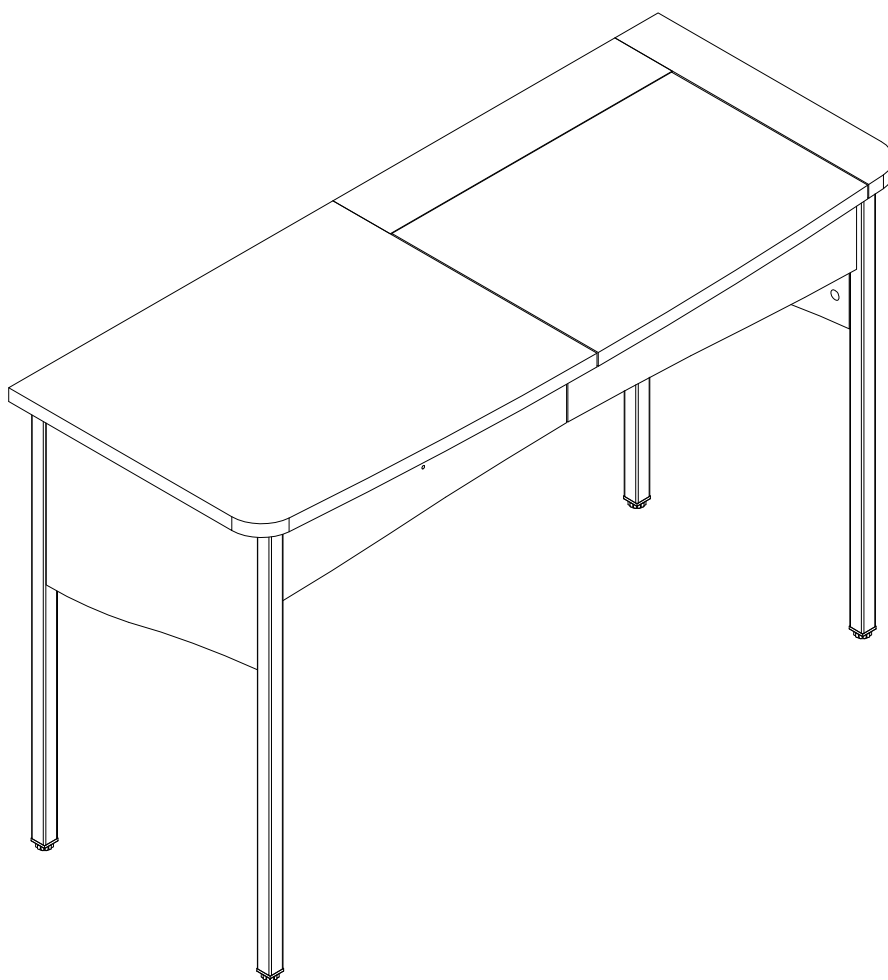

ТР ТС 025/2012

Декларация о соответствии ЕАЭС № ВУ/112 11.01. ТР025 009.01 01706  
от 17.04.2023 г., действительна до 16.04.2028 г. включительно

Телефон горячей линии 8 800 200 40 90 | Звонки по России бесплатные  
ASKONA.RU

## Перед сборкой





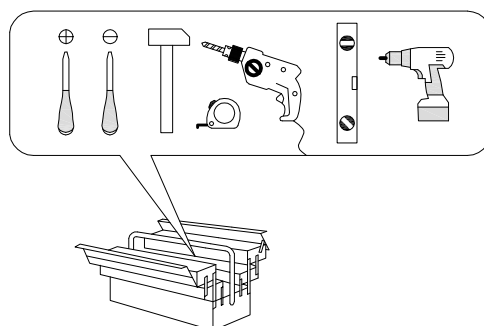





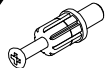



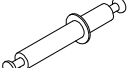
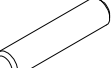



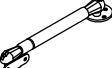

1. Проверить вид и целостность деталей в упаковке. Претензии по их повреждению принимаются только у изделий БЕЗ следов сборки.
2. Сохраните упаковку до окончания сборки! При выявлении в процессе сборки брака и некомплектности изделия необходимо сохранить упаковку до момента выезда к Вам представителя торговой компании.
3. Проверьте количество деталей и фурнитуры по перечню комплекточной ведомости, разберите фурнитуру на группы. Предприятие-изготовитель оставляет за собой право вносить конструктивные изменения в изделие, заменять фурнитуру и метизы на аналогичные, не ухудшающие внешний вид и не влияющие на функциональные свойства изделия.
4. Соблюдайте порядок сборки, данный в этой инструкции! При несоблюдении инструкций по сборке и эксплуатации с компании-производителя снимаются гарантийные обязательства. Инструкции по сборке и эксплуатации необходимо сохранять на весь период эксплуатации изделия.
5. Перемещайте все детали бережно, без рывков, укладывайте устойчиво, избегайте их падений и ударов! Сборку изделия проводить на ровной поверхности.

## Для сборки вам понадобится:

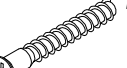

<b>RU</b>	Чтобы предотвратить опрокидывание, <b>ВСЕГДА</b> крепите мебель к стене! Входящие в комплект поставки материалы для крепления на стене (дюбели и шурупы) предназначены только для прочных бетонных стен. Для других типов стен используйте специальные дюбели и шурупы. При необходимости обратитесь за помощью в специализированный магазин.
<b>GB</b>	The enclosed wall mounting materials (dowels and screws) are only suitable for solid masonry (e.g. concrete or brick walls). Special dowels and other screws may be necessary for other wall constructions. If necessary, please consult a qualified professional.
<b>D</b>	Das beidseitige Wandbefestigungsmaterial (Dübel und Schrauben) eignet sich nur für festes Mauerwerk (z.B. Beton oder Ziegelwände). Für andere Wandaufbauten sind eventuell Spezialdübel und andere Schrauben notwendig. Ziehen Sie gegebenenfalls eine Fachkraft zurate.
<b>FR</b>	Le matériel de fixation murale fourni (chevilles et vis) convient uniquement à des murs solides (p. ex. murs en béton ou en briques). Pour les autres constructions de murs, il faut éventuellement des chevilles spéciales et d'autres vis. Faites-vous conseiller par un spécialiste.
<b>IT</b>	I materiali di fissaggio allegati (tasselli e viti) sono adatti solo ai muri compatti (ad es. di calcestruzzo o mattoni). Per altri tipi di pareti è probabile che occorran tasselli speciali e altre tipologie di viti. Richiedere eventualmente il consiglio di un esperto.
<b>NL</b>	Het bijgeleverde bevestigingsmateriaal (pluggen en schroeven) is geschikt voor vaste muren (bijv. betonnen of bakstenen muren). Voor andere muurconstructies zijn eventueel speciale pluggen en andere schroeven noodzakelijk. Consulteer eventueel een vakman.
<b>CZ</b>	Příložený materiál pro montáž na stěnu (hmoždinky a šrouby) je vhodný jen pro pevné zdivo (např. betonové nebo cihlové stěny). Pro jiné skladby stěn budou případně nutné speciální hmoždinky a jiné šrouby. Poradte s odborníkem.
<b>PL</b>	Żalączony zestaw montażowy do zamocowania artykułu do ściany (kołki, wkręty, haki itp.), przeznaczony jest do montażu artykułu na ścianach wykonanych z cegły lub betonu. Przy montażu artykułu na ścianie wykonanej z innych materiałów, należy zastosować odpowiednie do niej zamocowania. W razie wątpliwości prosimy zasięgnąć porady fachowca.
<b>SK</b>	Priložený materiál pre upevnenie na stenu (hmoždinky a skrutky) je vhodný len pre pevné murivo (napr. betónové alebo tehlové steny). Pre iné steny sú potrebné príp. špeciálne hmoždinky a iné skrutky. V prípade potreby sa poradte s odborníkom.
<b>HU</b>	A mellékelt fali rögzítőkészlet (tiplire és csavarok) csak tömött falazatban (pl. betonfalban, téglafalban) használható. Más faltípusokhoz speciális tiplire és csavarra lesz szükség. Szükség esetén kérje ki egy szakember véleményét.
<b>RO</b>	Materialul furnizat pentru montajul de perete (dibluri și șuruburi) este adecvat numai pentru zidărie solidă (de exemplu pereți din beton sau din cărămidă). Pentru alte structuri de pereți, este posibil să fie necesare dibluri special, precum și alte șuruburi. Dacă este necesar, consultați un specialist.
<b>TR</b>	Teslimat kapsamındaki duvar tipi sabitleme materyali (dübel ve vidalar) sadece beton ve tuğla duvarlar gibi sağlam duvar yapılar için uygundur. Başka duvar yapılar için özel dübeller veya başka vidalar gerekli. Gerekirse bir uzmandan yardım alın.

0  
10  
20  
30  
40  
50  
60  
70  
80  
90  
100

<b>A</b> 090913 7x32  <b>x22</b>	<b>B</b> 081320  <b>x8</b>	<b>C</b> 000146 15x12  <b>x16</b>	<b>D</b> 000147 15x16  <b>x22</b>	<b>E</b> 122925  <b>x4</b>	<b>F</b> 000151 8x35  <b>x20</b>
<b>G</b> 135021  <b>x4</b>	<b>H</b> 000759 3x20  <b>x4</b>	<b>I</b> 198478 L350  <b>x1</b>	<b>J</b> 000762 3.5x13  <b>x14</b>	<b>K</b> 098889  <b>x4</b>	<b>L</b> 329812  <b>x1</b>
<b>M</b> 002704 M4x20  <b>x1</b>	<b>N</b> 210316  <b>x2</b>	<b>O</b> 000763 3.5x16  <b>x18</b>	<b>P</b> 113834  <b>x2</b>	<b>Q</b> 101608 7x50  <b>x14</b>	<b>R</b> 231885 25x25  <b>x4</b>
<b>S</b> 007085 M6  <b>x4</b>	<b>T</b> 098200  <b>x4</b>	<b>U</b> 000769 2.5x20  <b>x4</b>	<b>V</b> 100640 20x0.5  <b>x15</b>		

N	Size/MaB (mm)	Qty	✓	N	Size/MaB (mm)	Qty	✓
1	302x392x22	1	1	9	472x75x16	1	1
2	302x392x22	1	1	10	1070x300x16	1	1
3	375x97x22	1	1	11	1070x375x16	1	1
4	375x97x22	1	1	12	482x343x3	1	1
5	530x134x16	1	1	13	599x488x22	1	1
6	534x134x16	1	1	14	80x469x22	1	1
7	350x75x16	1	1	15	521x488x26	1	1
8	350x75x16	1	1	16	718x25x25	2	2
				17	718x25x25	2	2

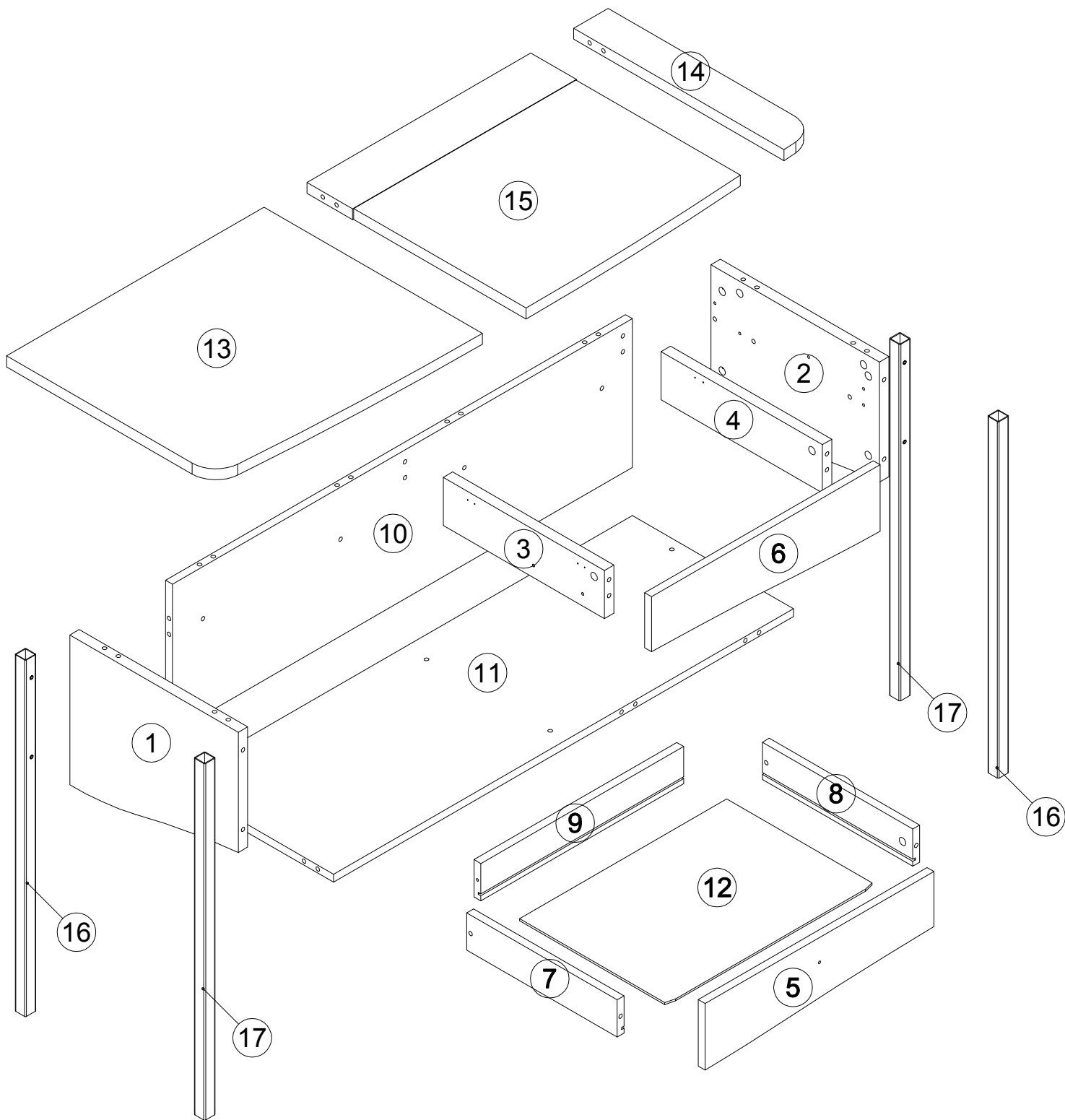

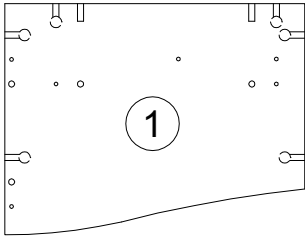

302x392x22

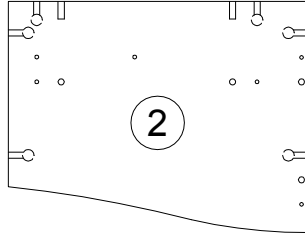

302x392x22

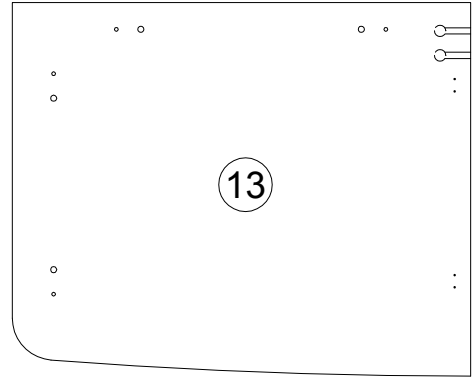

599x488x22

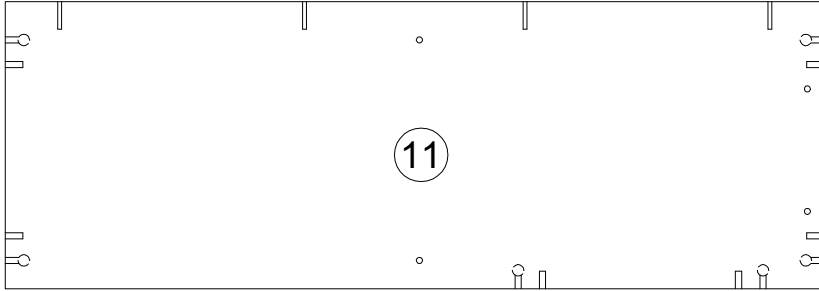

1070x375x16

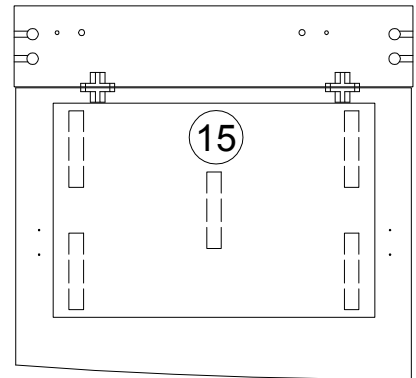

521x488x26

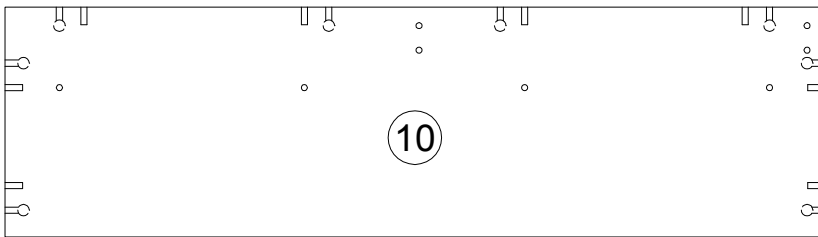

1070x300x16



80x469x22



718x25x25



718x25x25

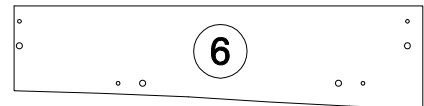

534x134x16



375x97x22



375x97x22

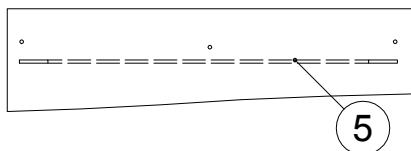

530x134x16

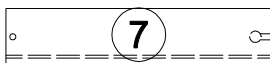

350x75x16

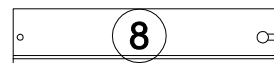

350x75x16

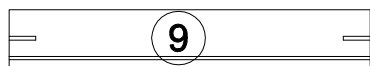

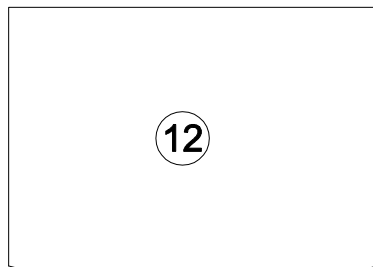

472x75x16





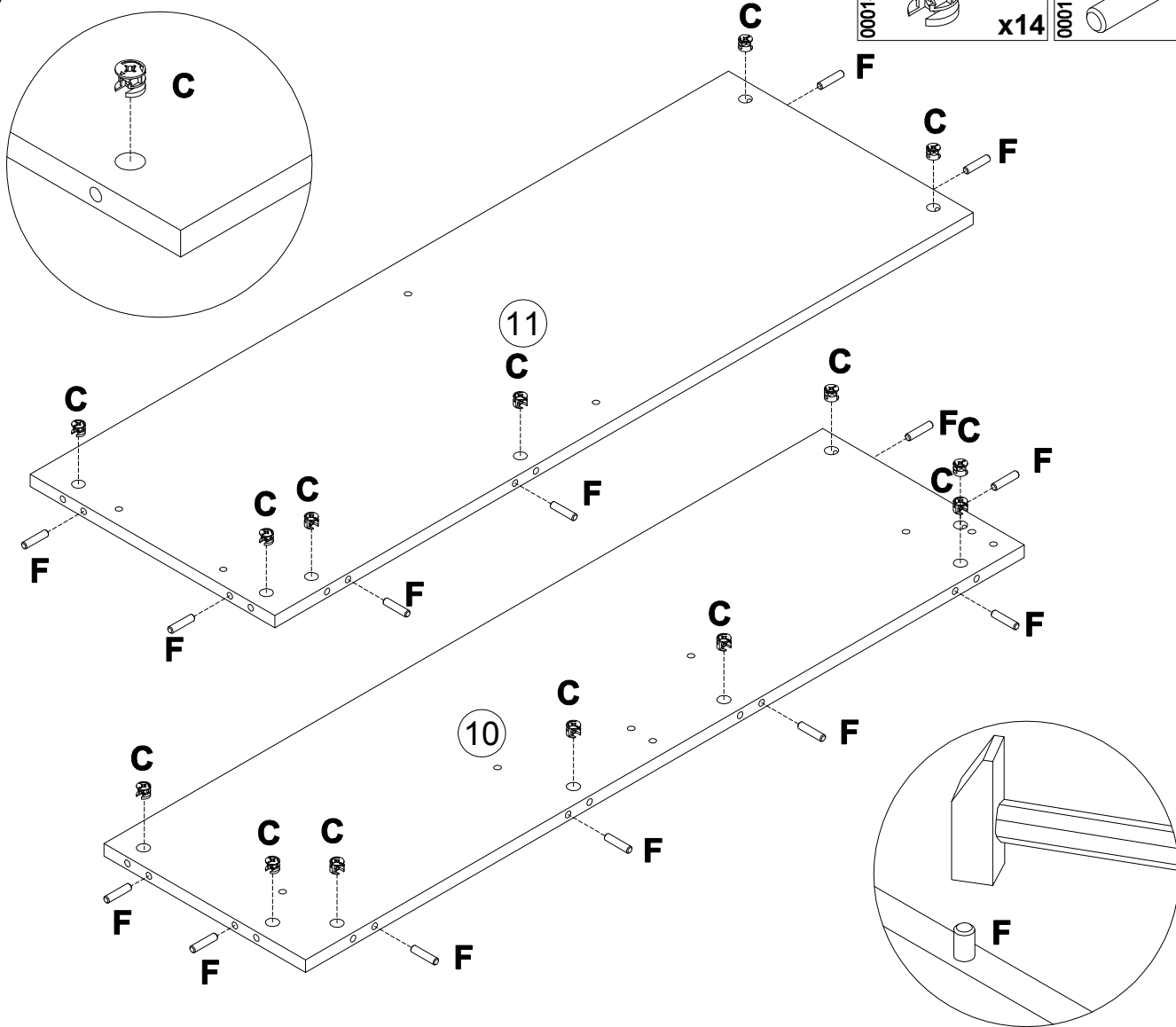

482x343x3

1

<b>C</b>	000146	15x12	<b>F</b>	8x35
				
		<b>x14</b>		<b>x14</b>

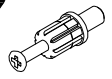

2

<b>A</b>	090913	7x32	<b>D</b>	000147	15x16	<b>O</b>	000763	3.5x16	<b>P</b>	113834	
											
		<b>x4</b>			<b>x2</b>			<b>x4</b>			<b>x2</b>

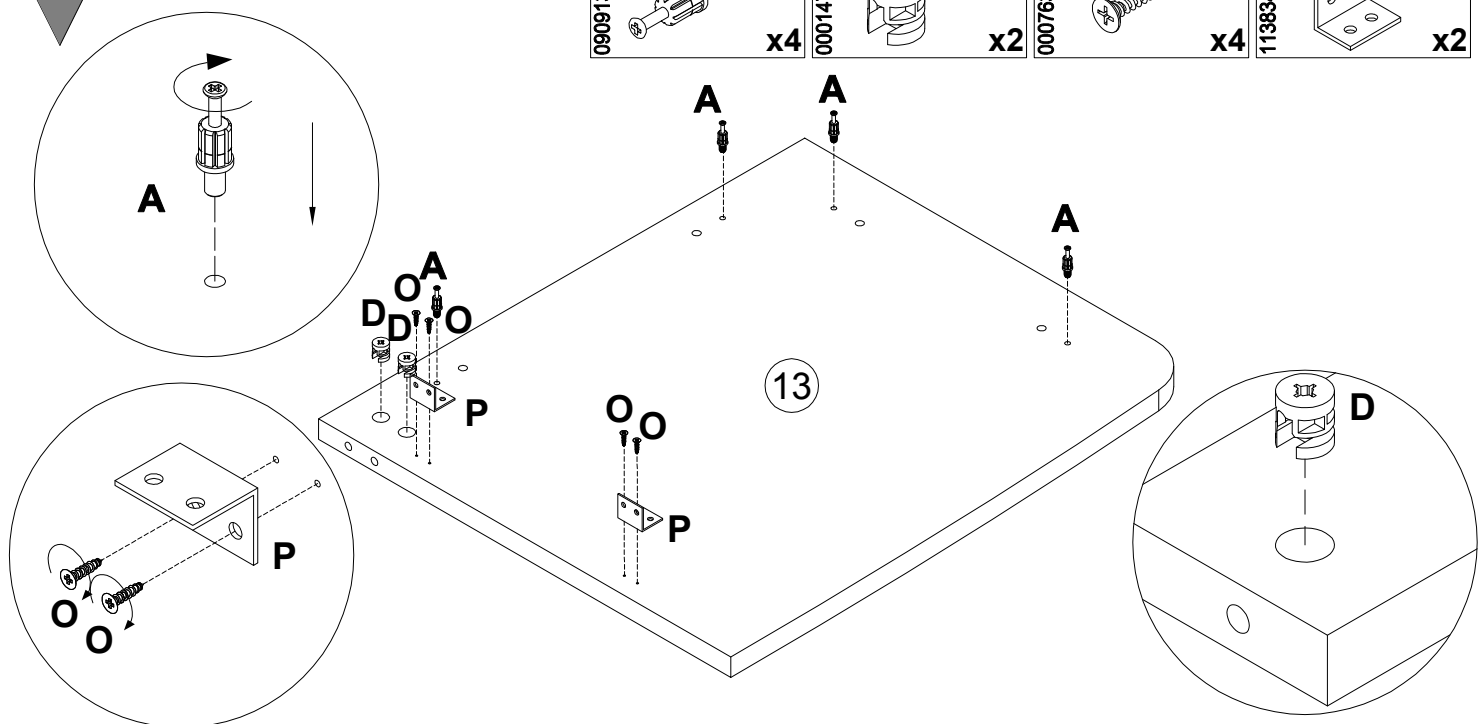



3

**A** 090913 7x32 x2

**D** 000147 15x16 x4

**N** 210316 x2

**O** 000763 3.5x16 x4

**T** 098200 x4

**U** 000769 2.5x20 x4

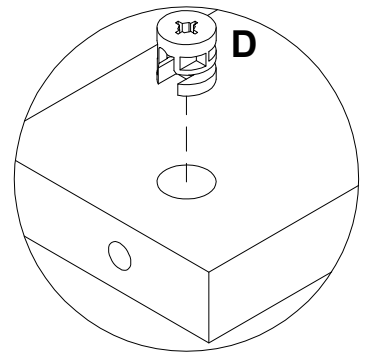
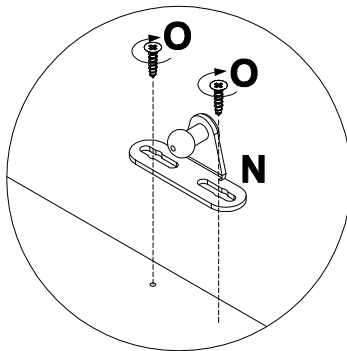
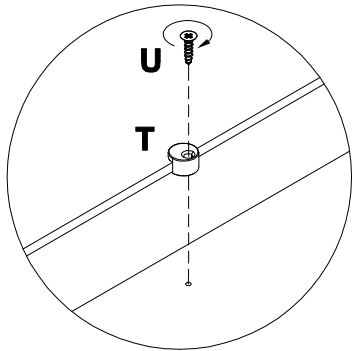
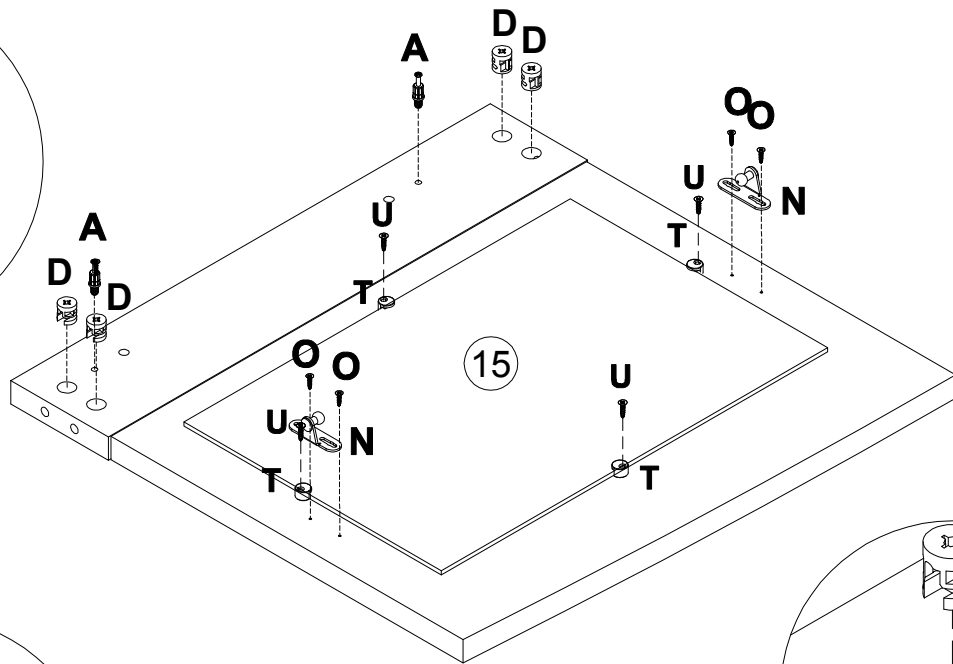
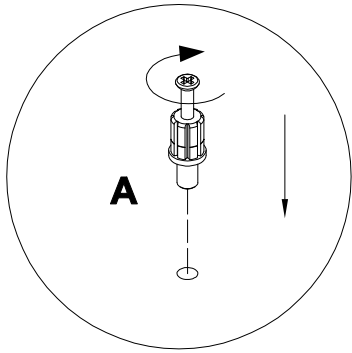

4

**D** 000147 15x16 x1

**F** 000151 8x35 x1

**N** 210316 x1

**O** 000763 3.5x16 x3

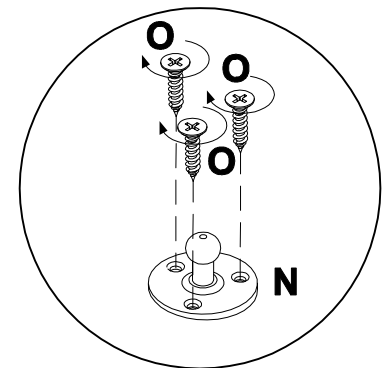
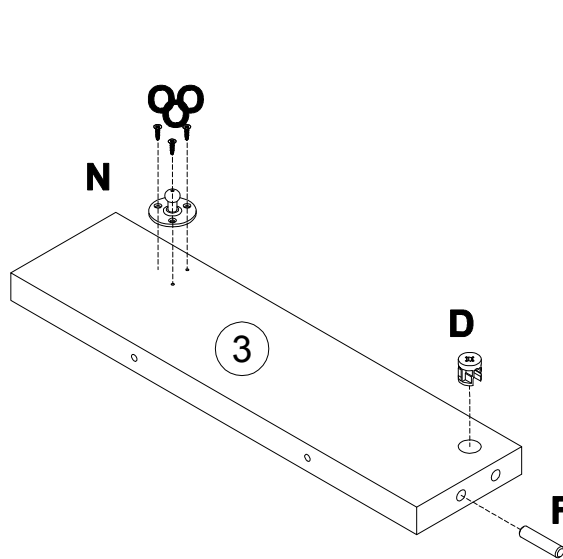
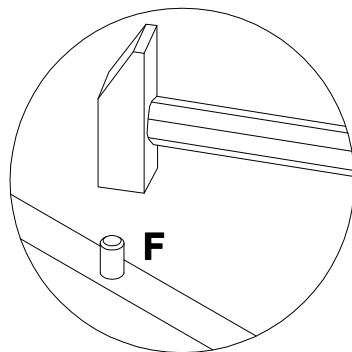
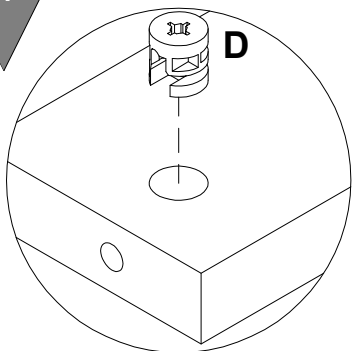

5

<b>A</b> 090913	7x32 x8	<b>D</b> 000147	15x16 x13	<b>F</b> 000151	8x35 x5	<b>N</b> 210316	x1	<b>O</b> 000763	3.5x16 x3
--------------------	------------	--------------------	--------------	--------------------	------------	--------------------	----	--------------------	--------------

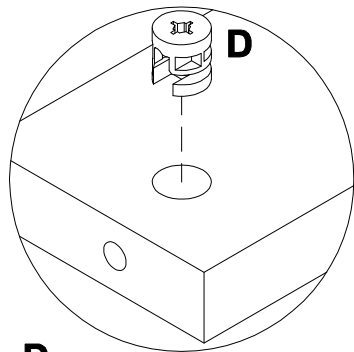
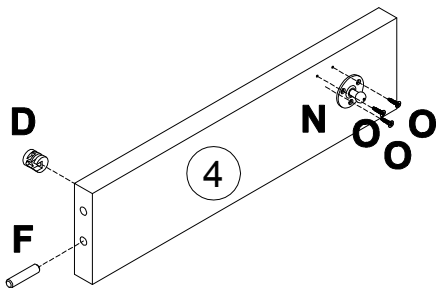
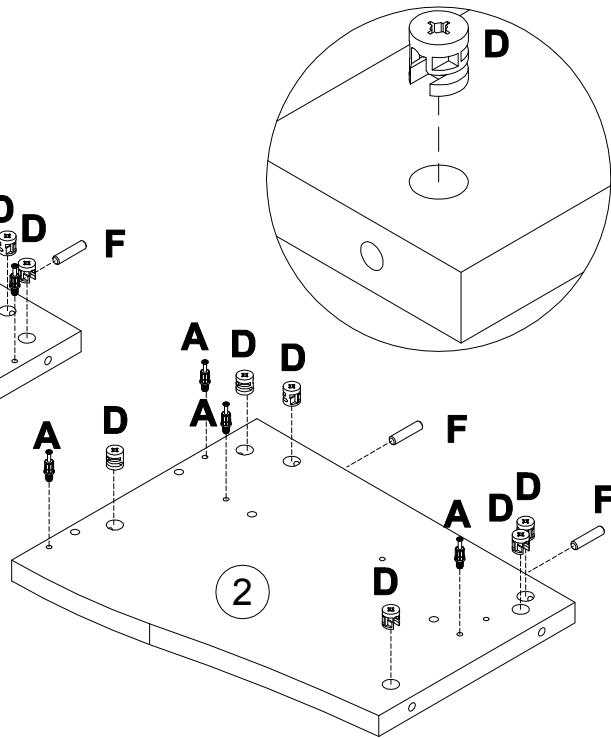
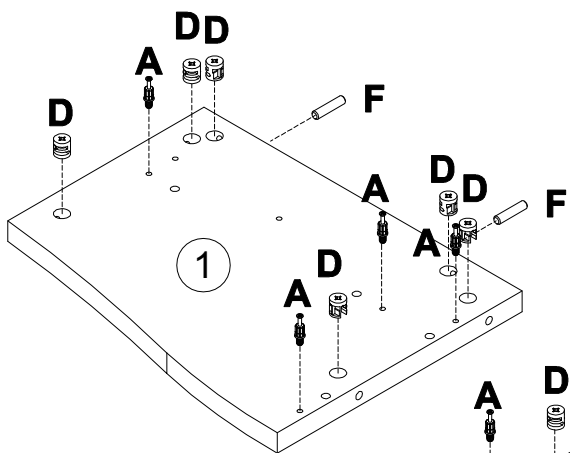
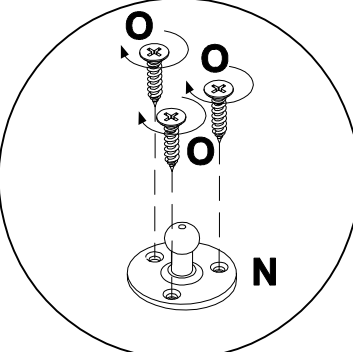
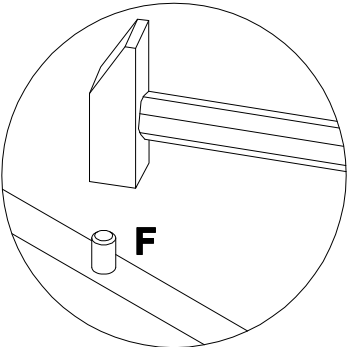
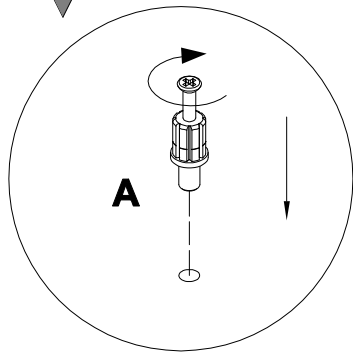

6

<b>A</b> 090913	7x32 x6	<b>D</b> 000147	15x16 x2
--------------------	------------	--------------------	-------------

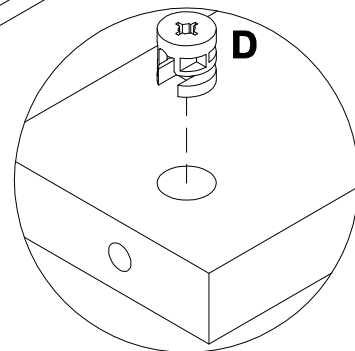
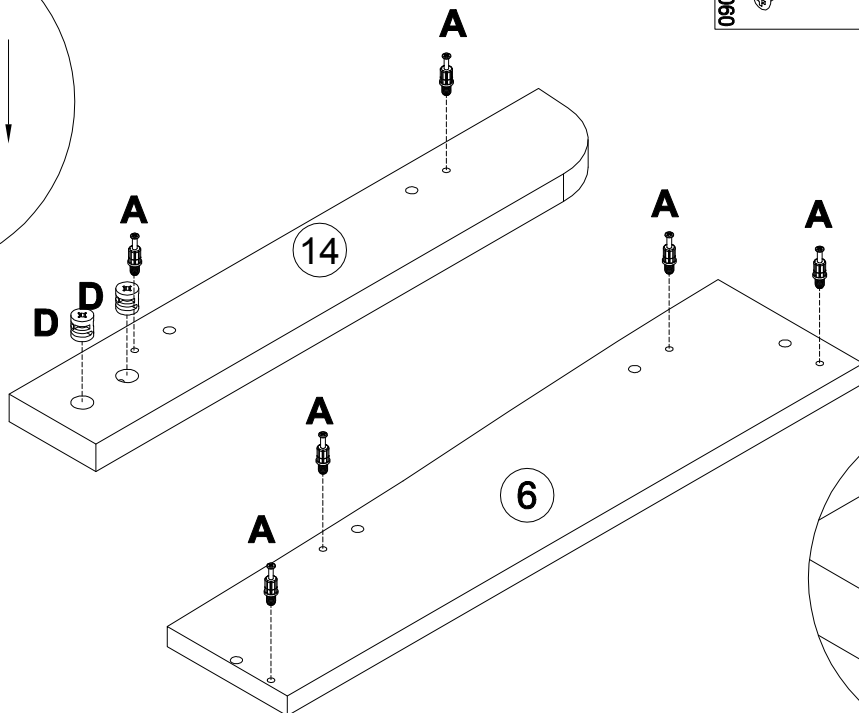
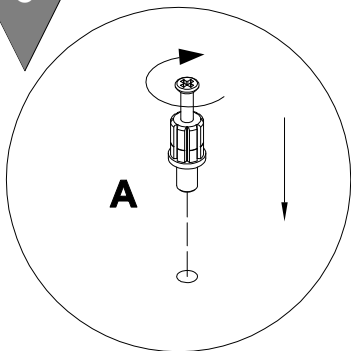

7

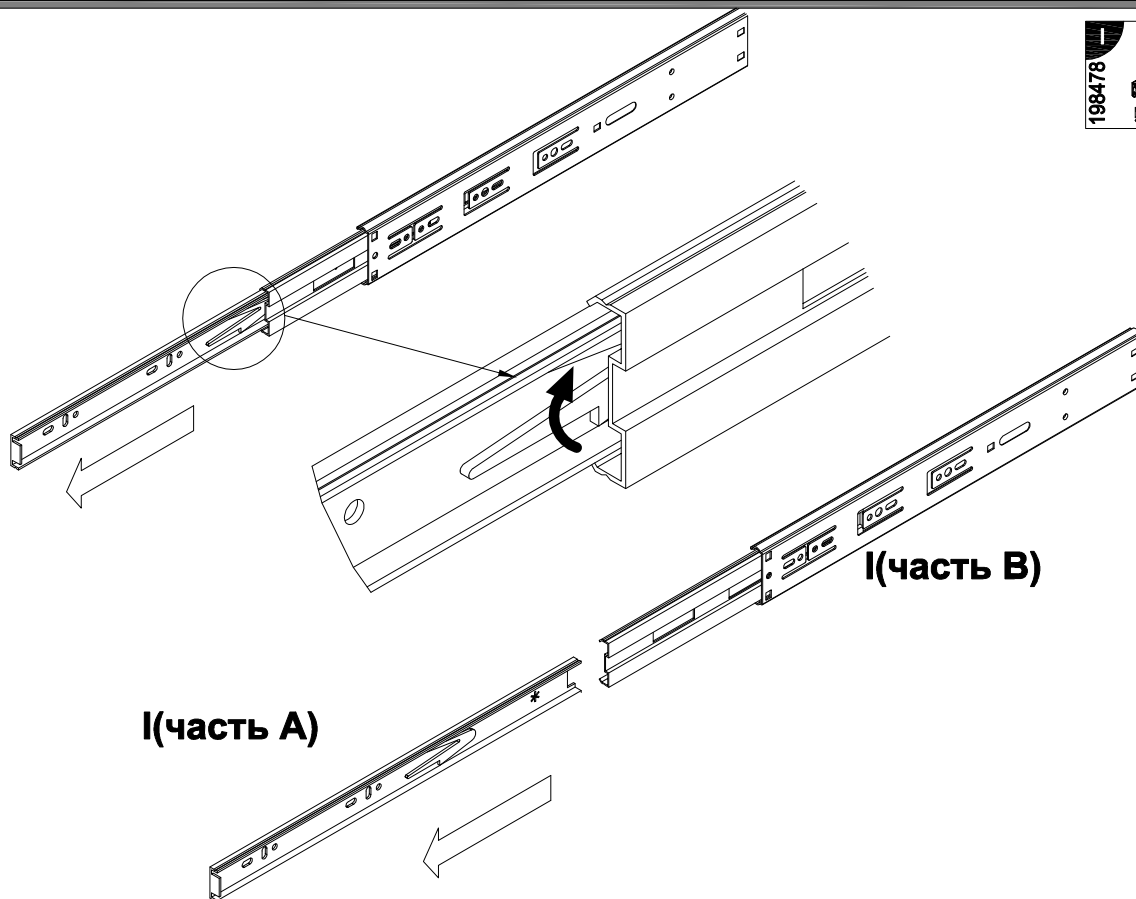
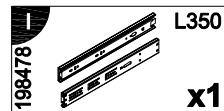

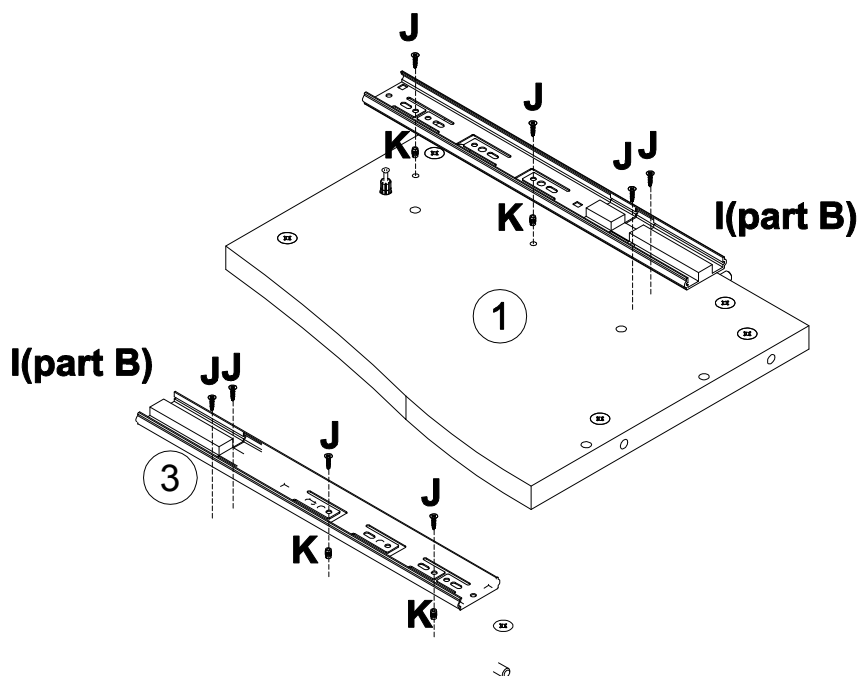
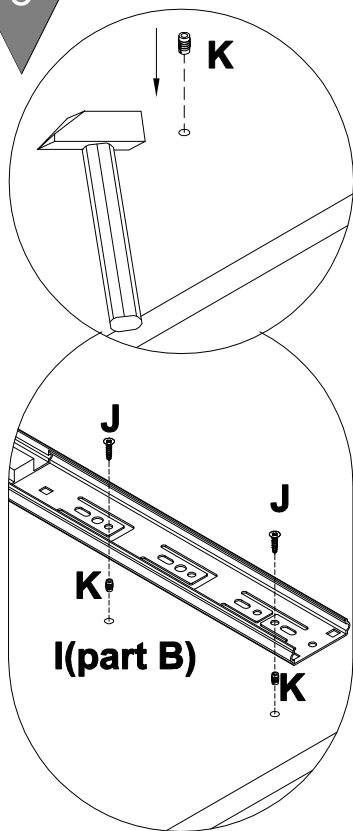
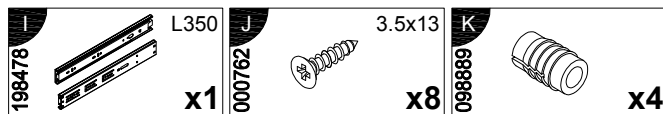

8

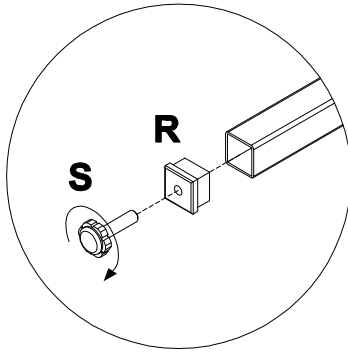
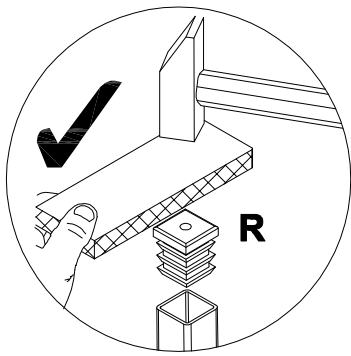

9

x2

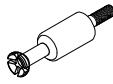

<b>B</b> 081320		<b>x8</b>	<b>R</b> 231885		25x25	<b>x4</b>	<b>S</b> 007085		M6	<b>x4</b>
--------------------	------------------------------------------------------------------------------------	-----------	--------------------	-------------------------------------------------------------------------------------	-------	-----------	--------------------	-------------------------------------------------------------------------------------	----	-----------

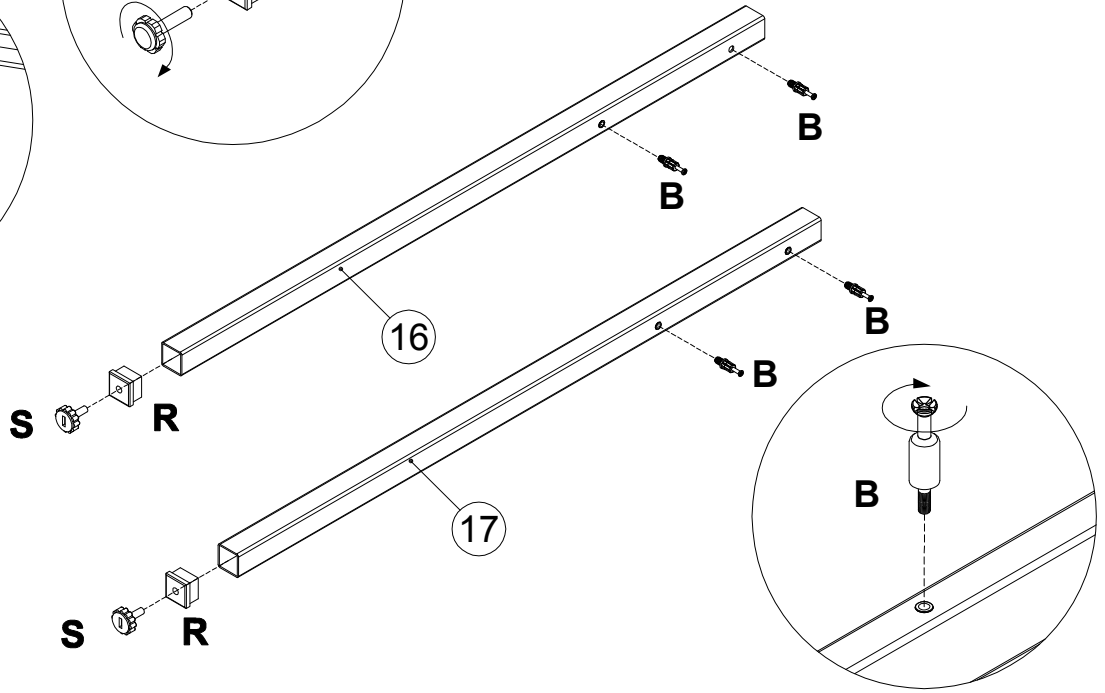
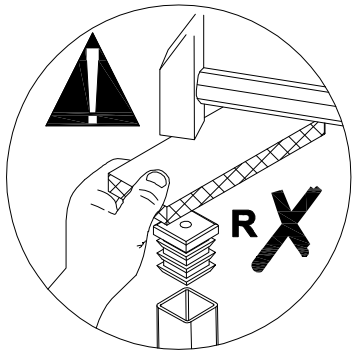

10

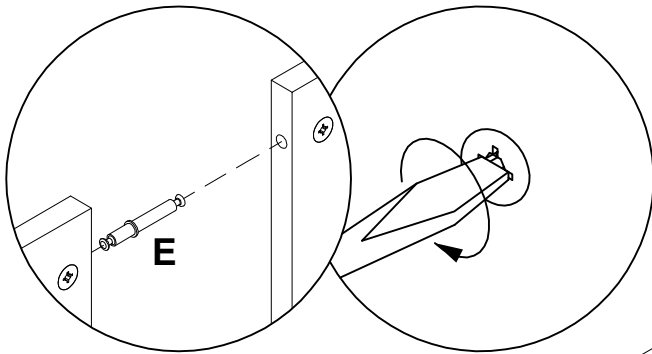

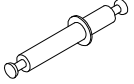
<b>E</b> 122925		<b>x4</b>
--------------------	---------------------------------------------------------------------------------------	-----------

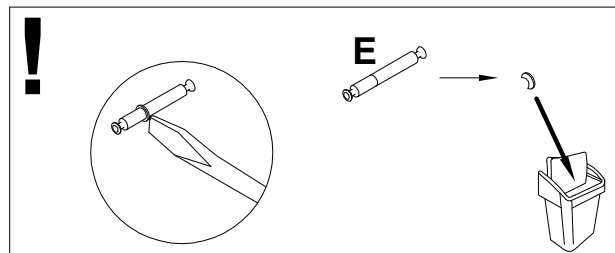
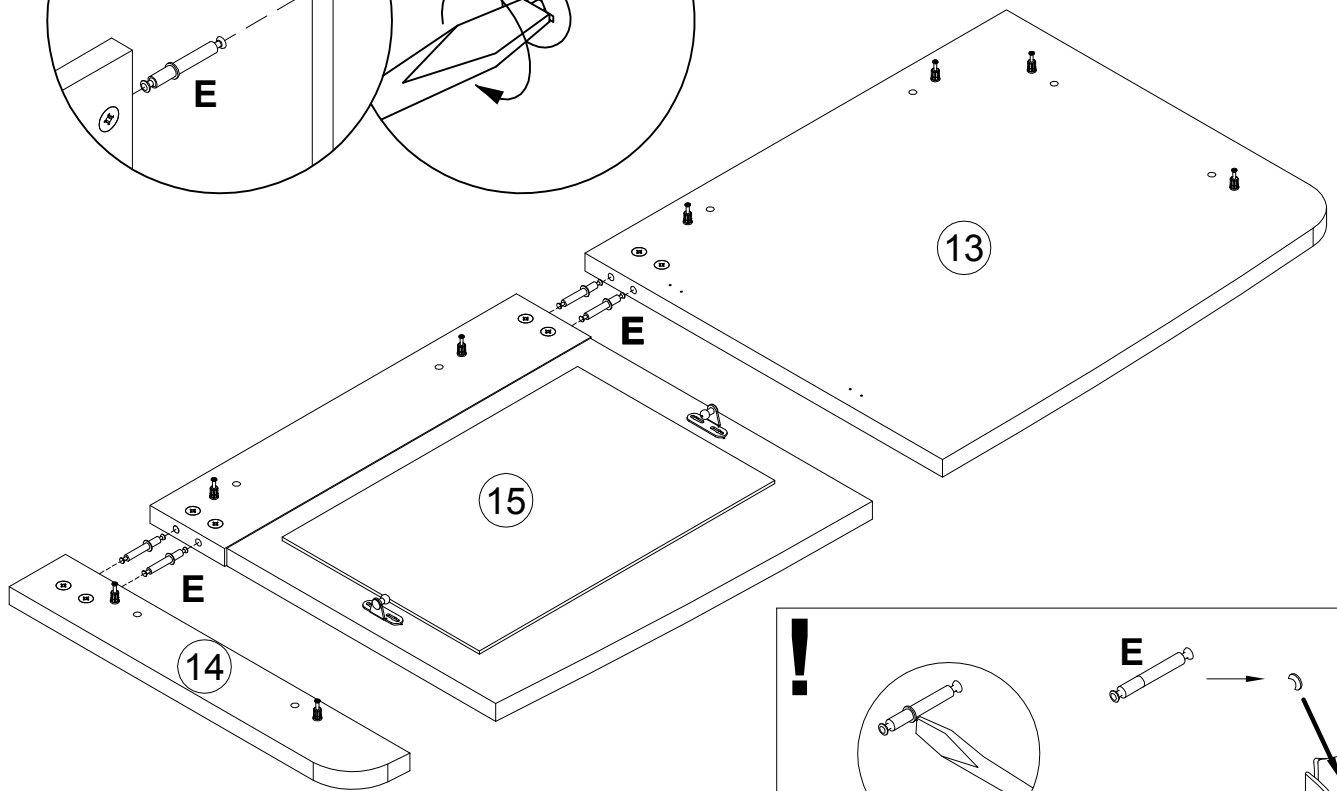

11

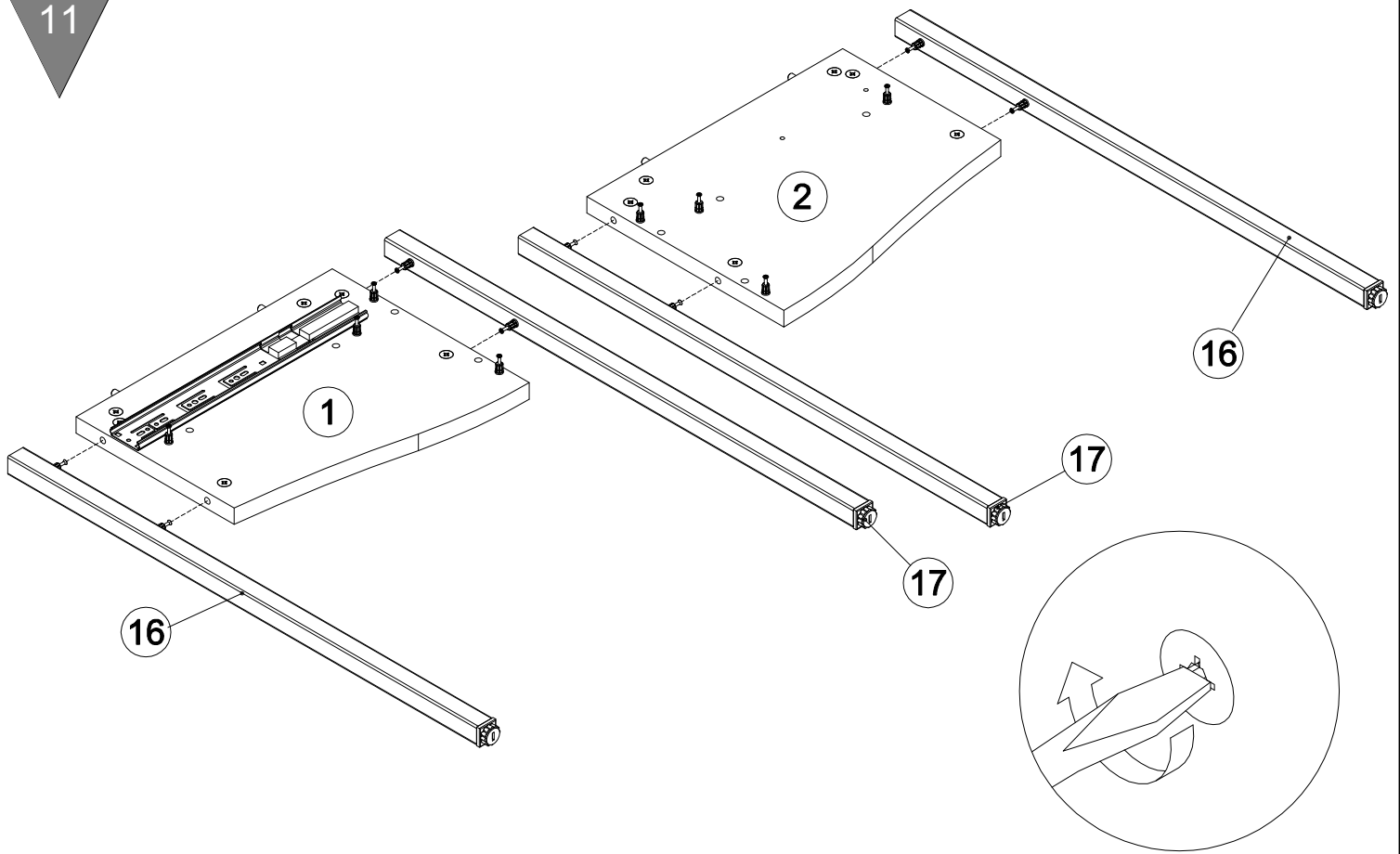

12

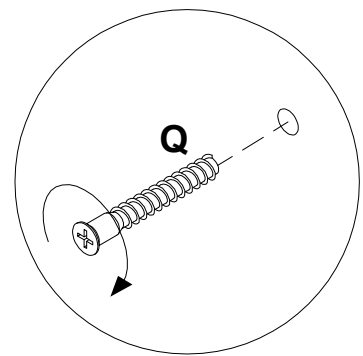
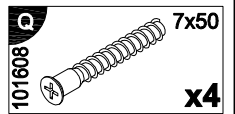
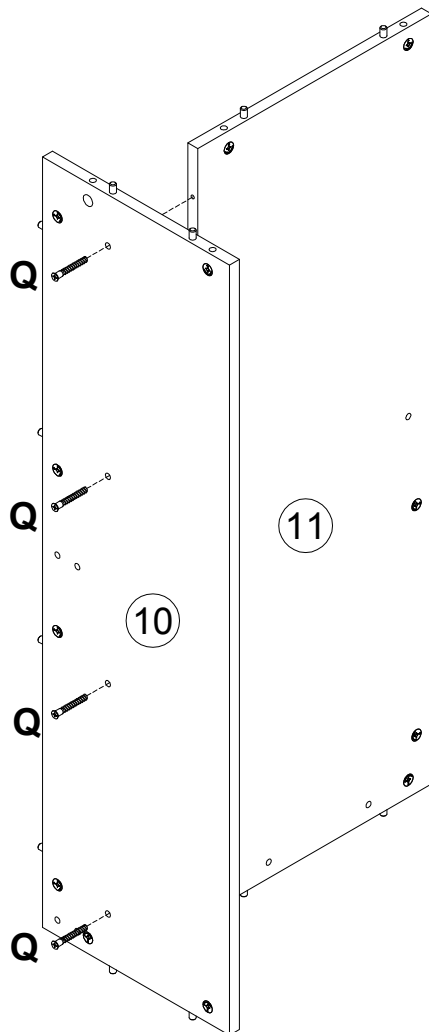

13

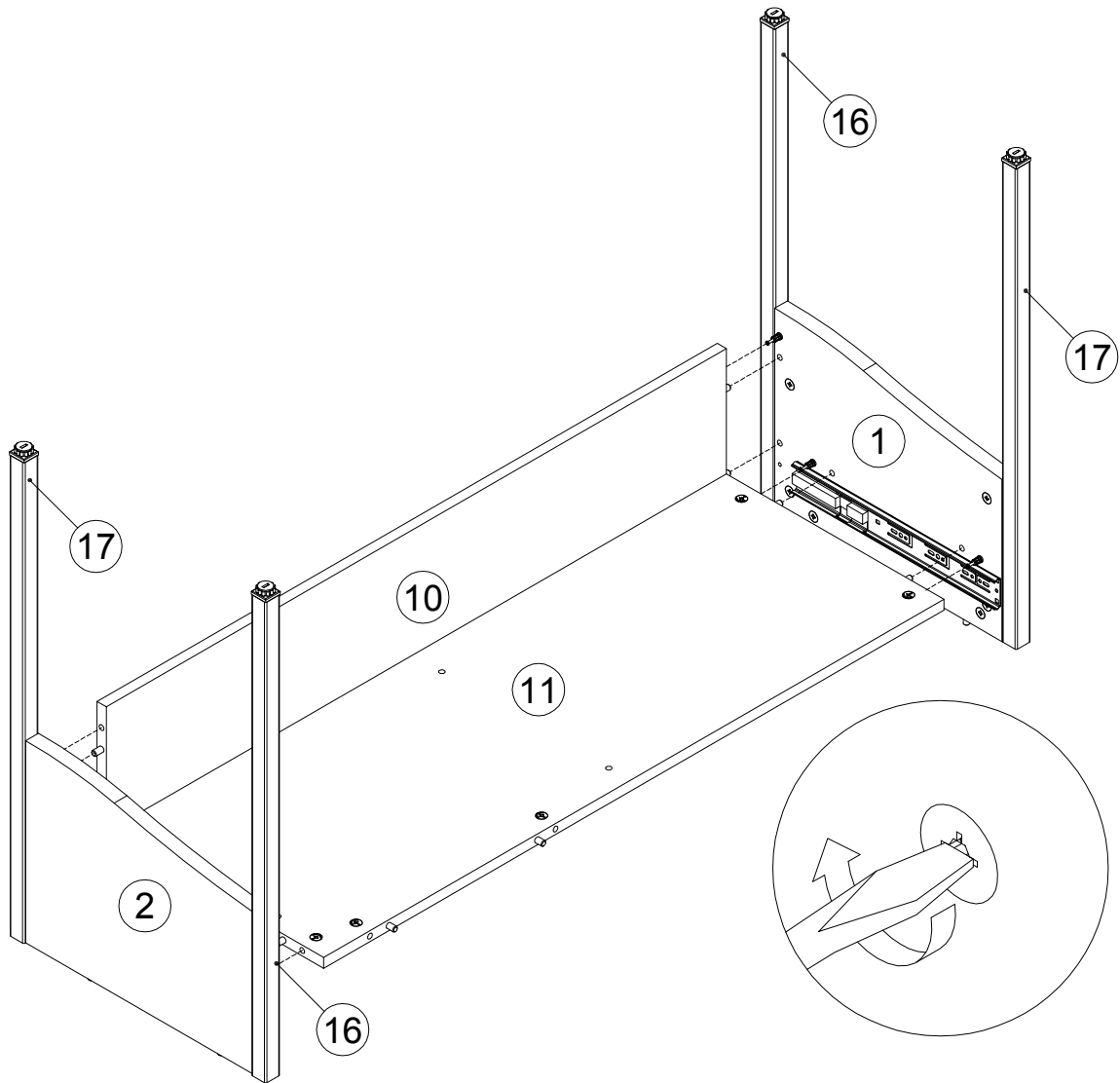

14

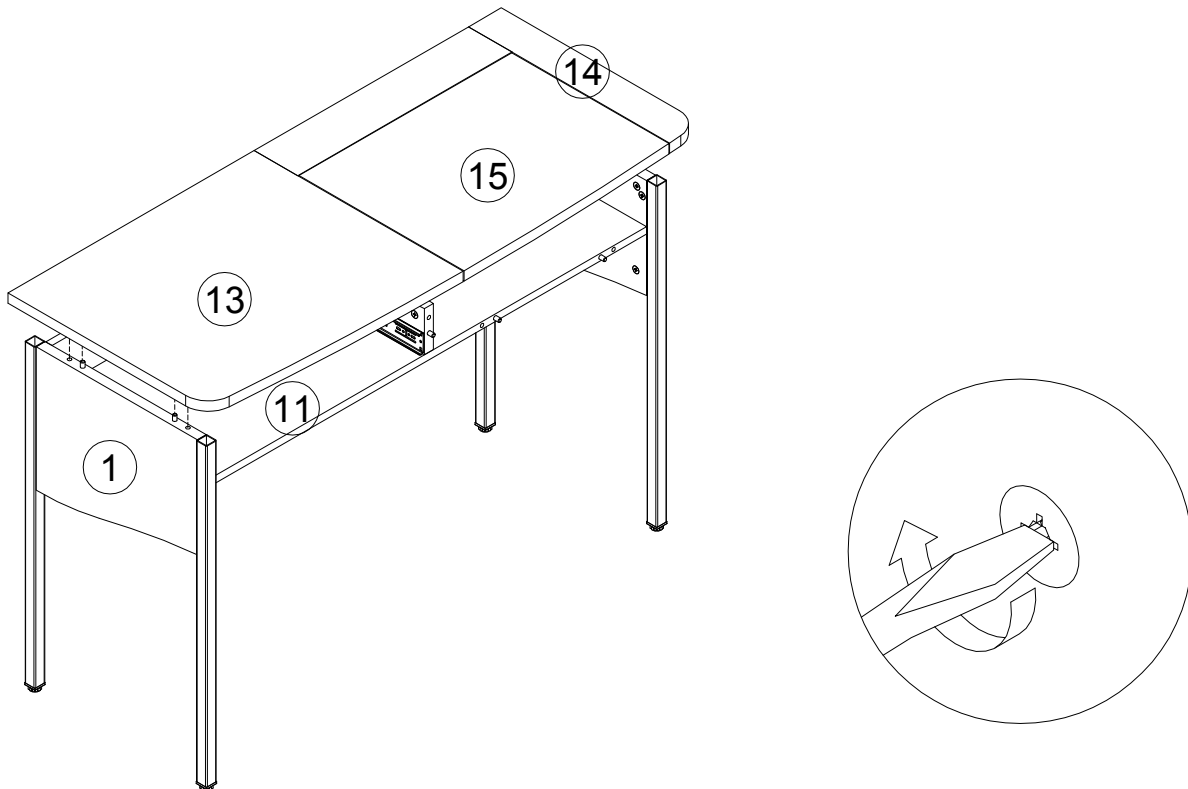

15

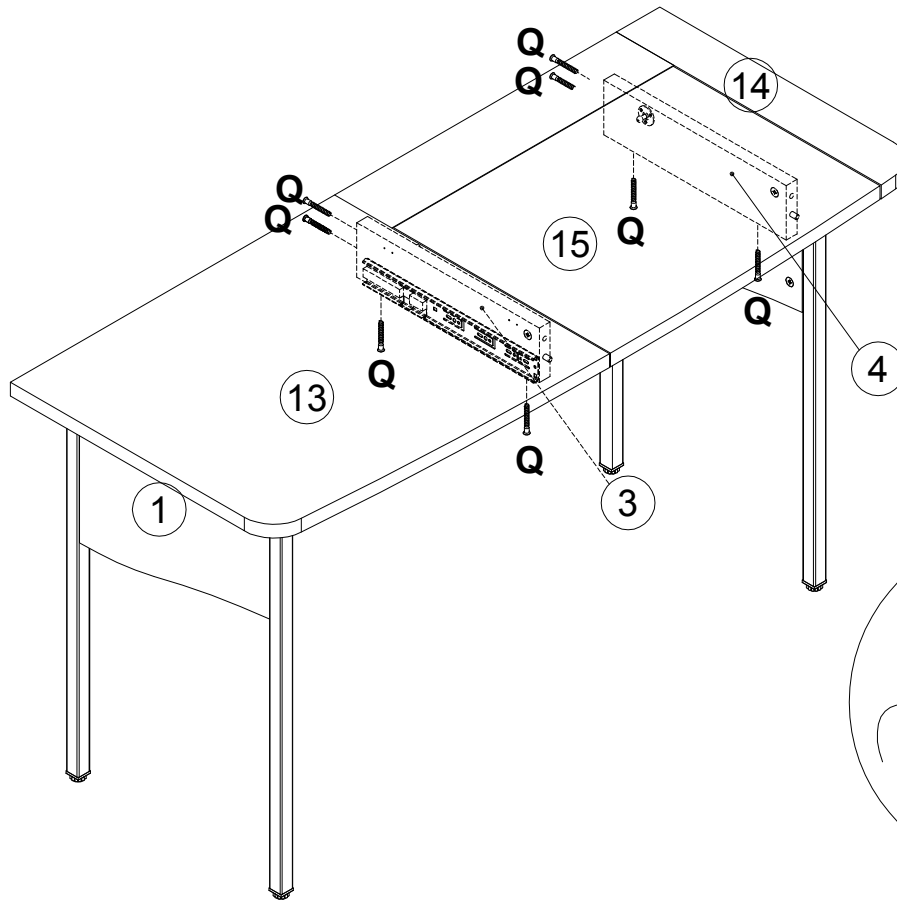

101608 **Q** 7x50  
x8

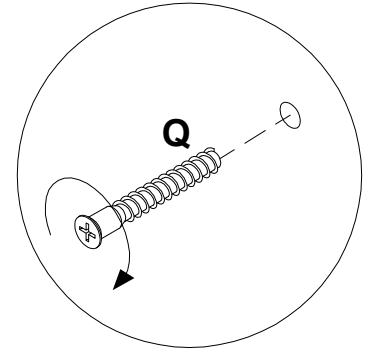

16

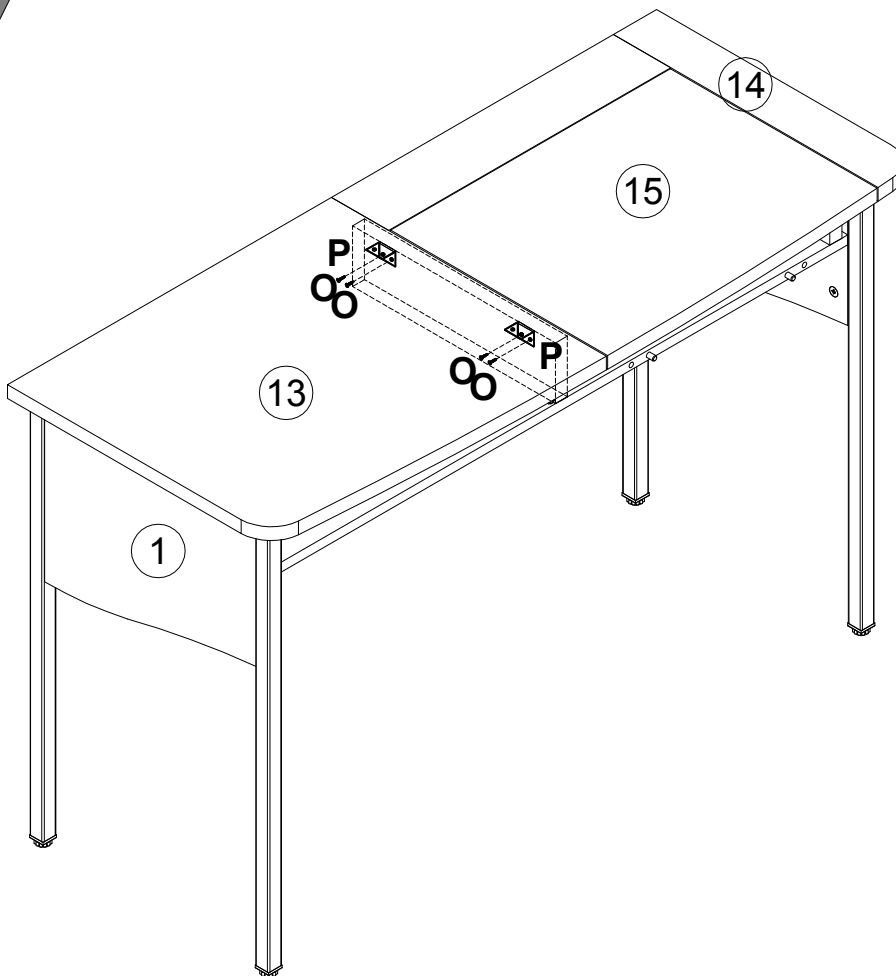

000763 **O** 3.5x16 x4  
113834 **P** x2

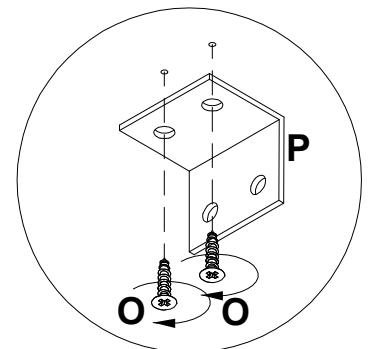

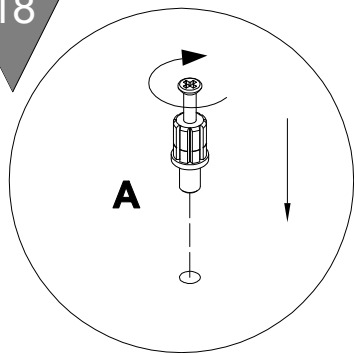
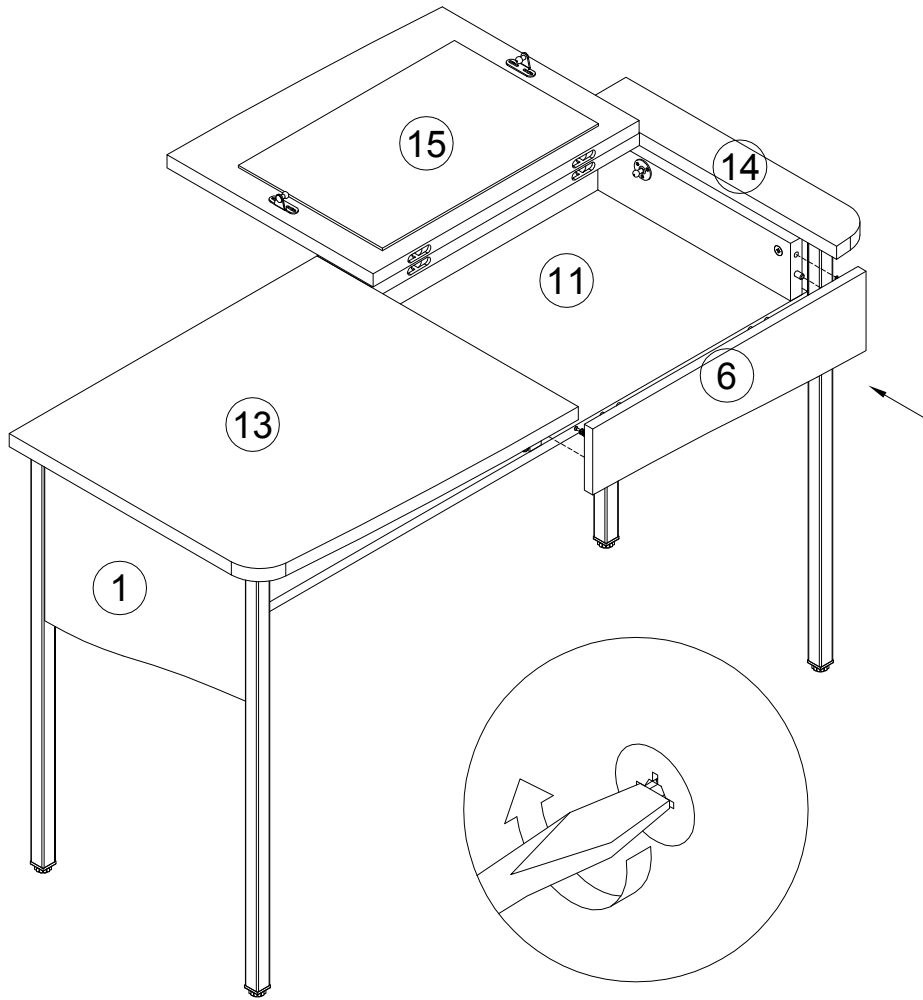

<b>A</b>		7x32	<b>C</b>		15x12	<b>L</b>		x1	<b>M</b>		M4x20
	090913	x2	000146	x2	329812	x1	002704	x1			

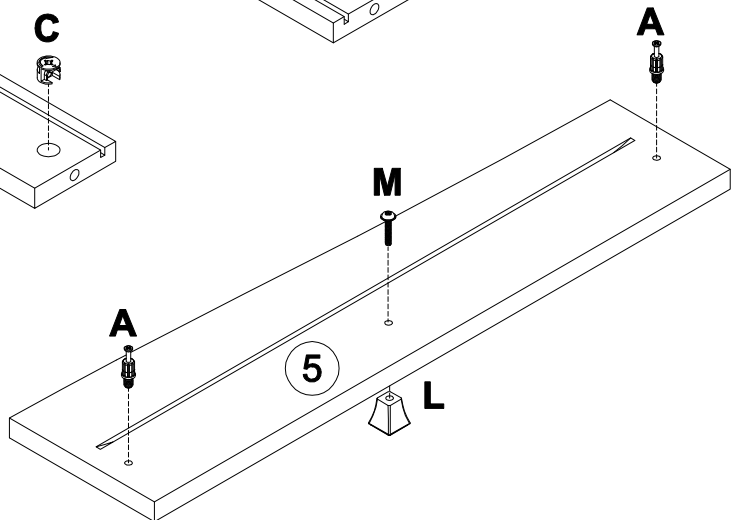
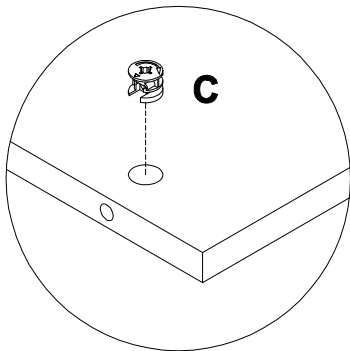
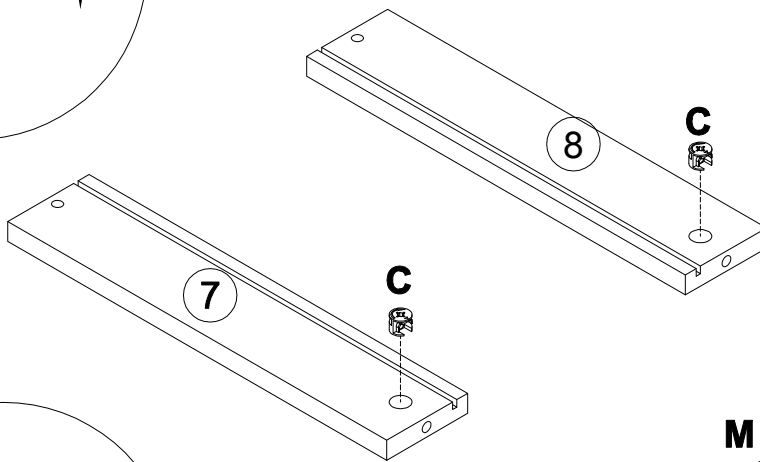
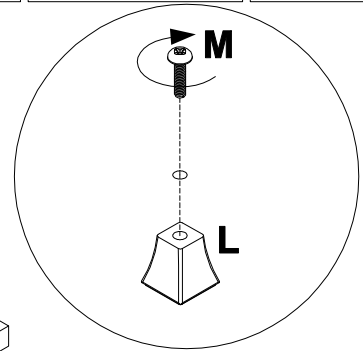



19

101608  7x50  
x2

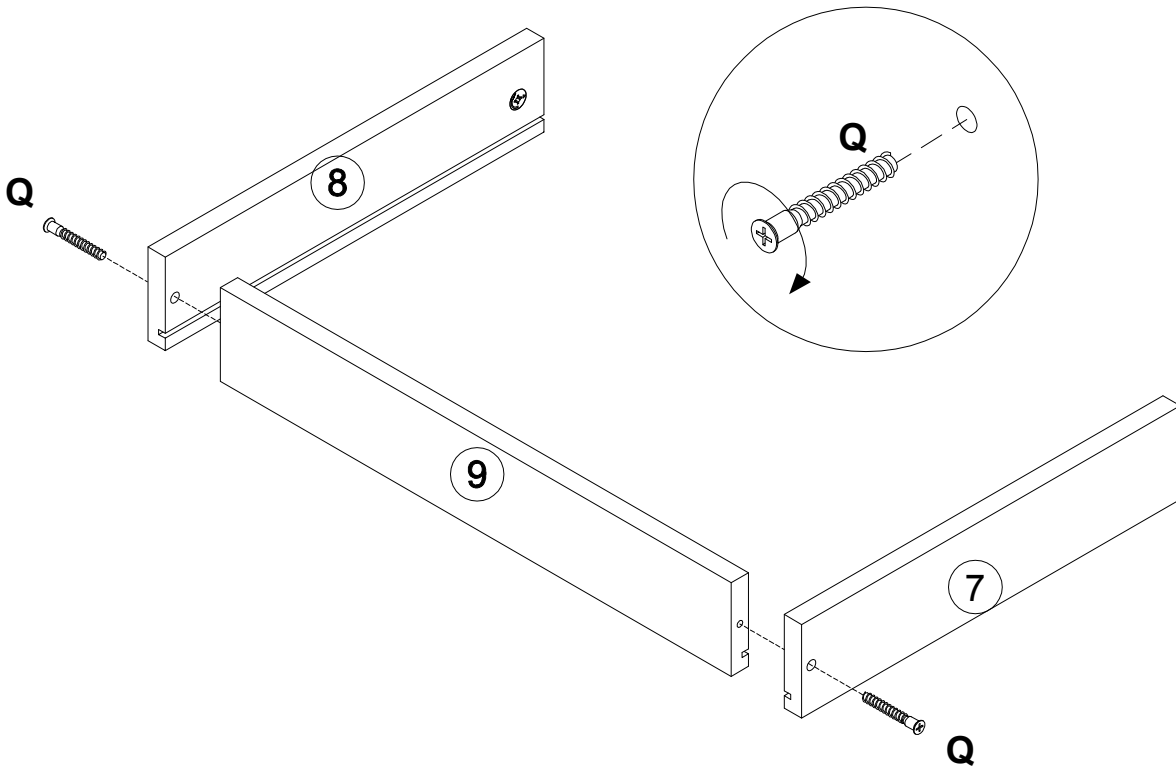

20

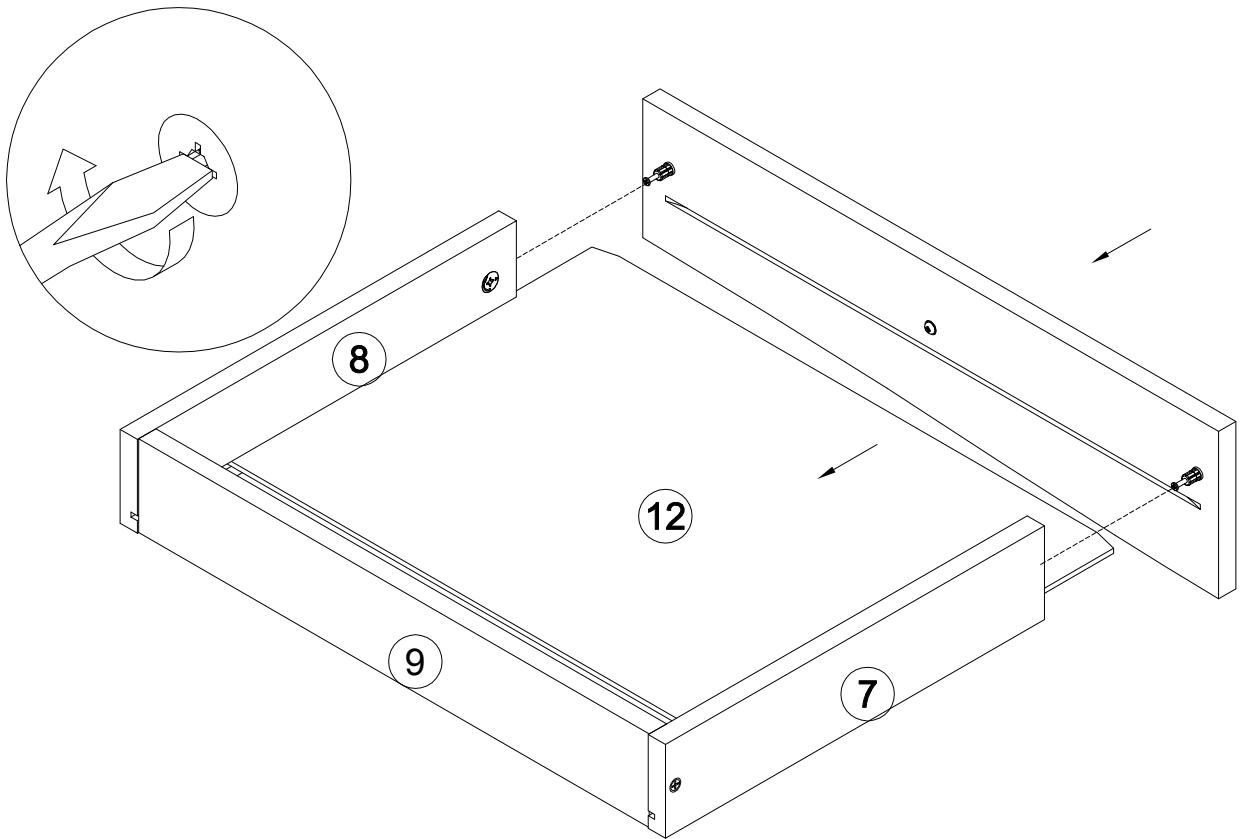

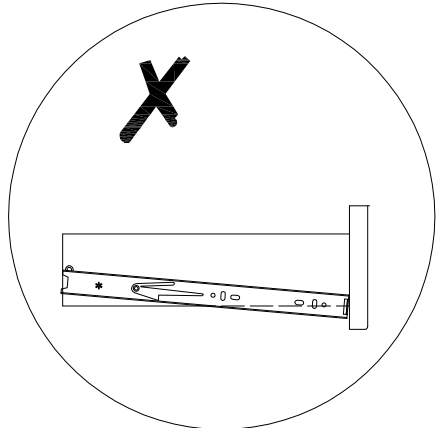
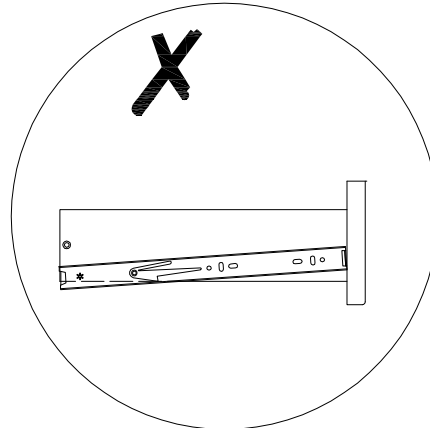
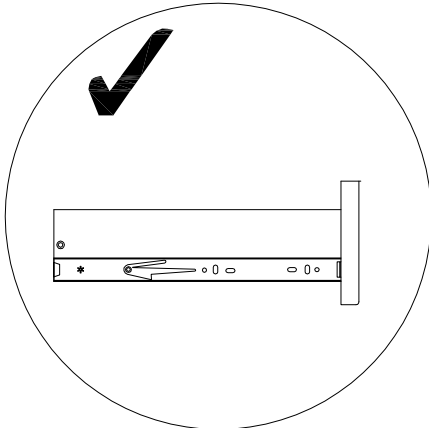
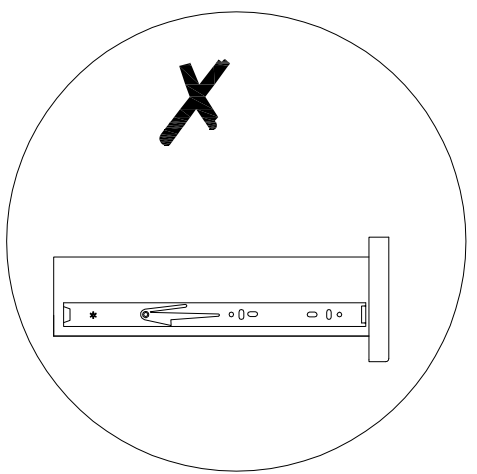
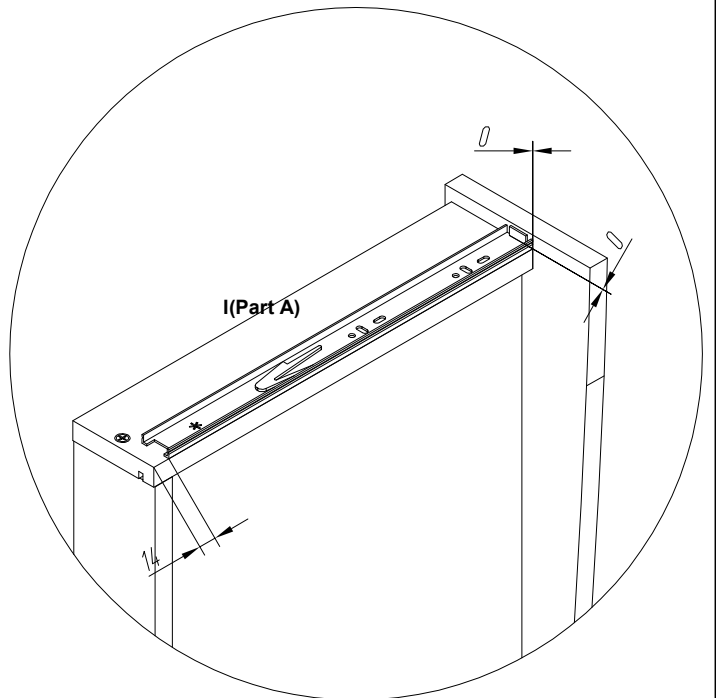
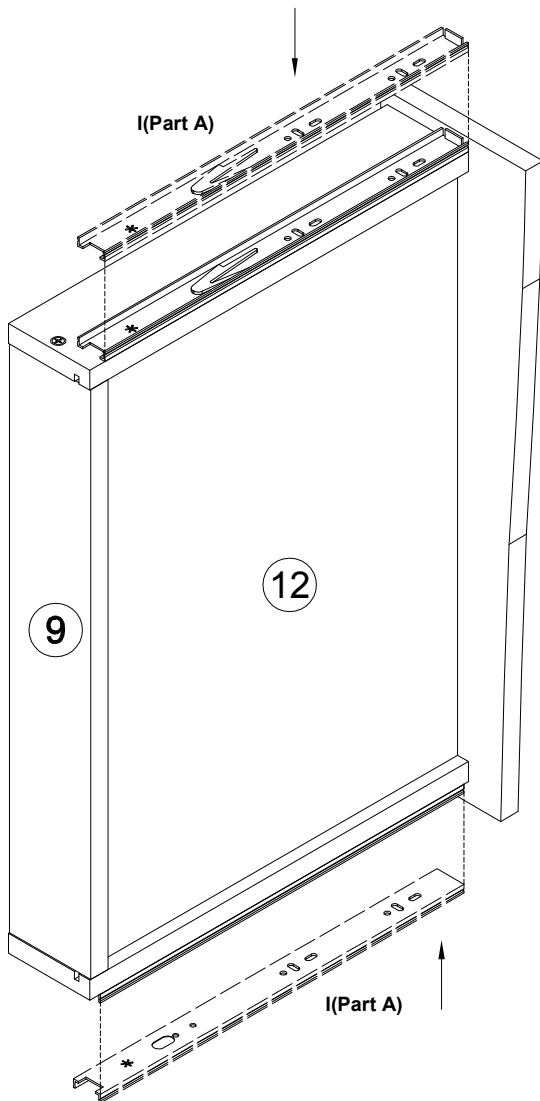

22

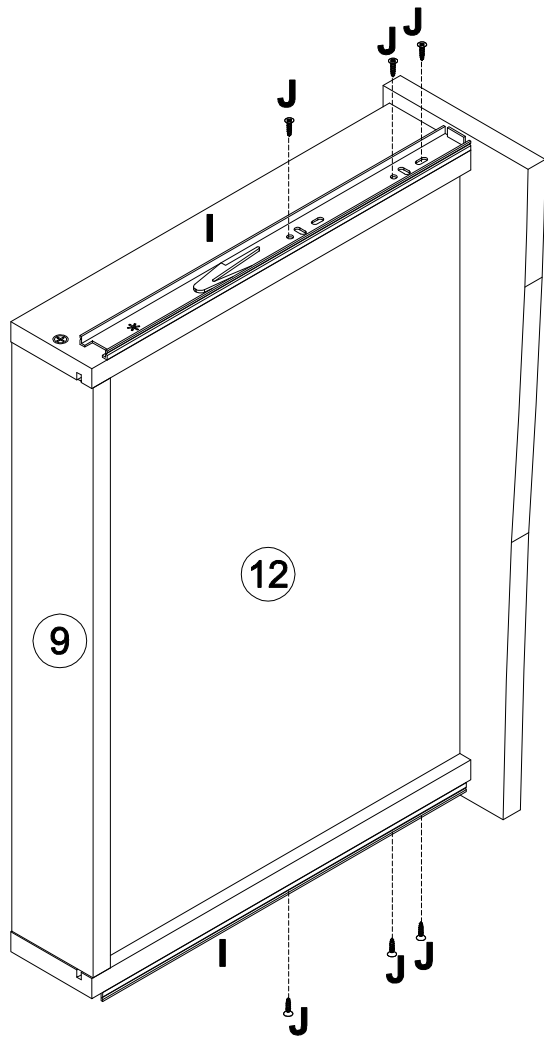

198478	L350	J	3.5x13
	x1		x6

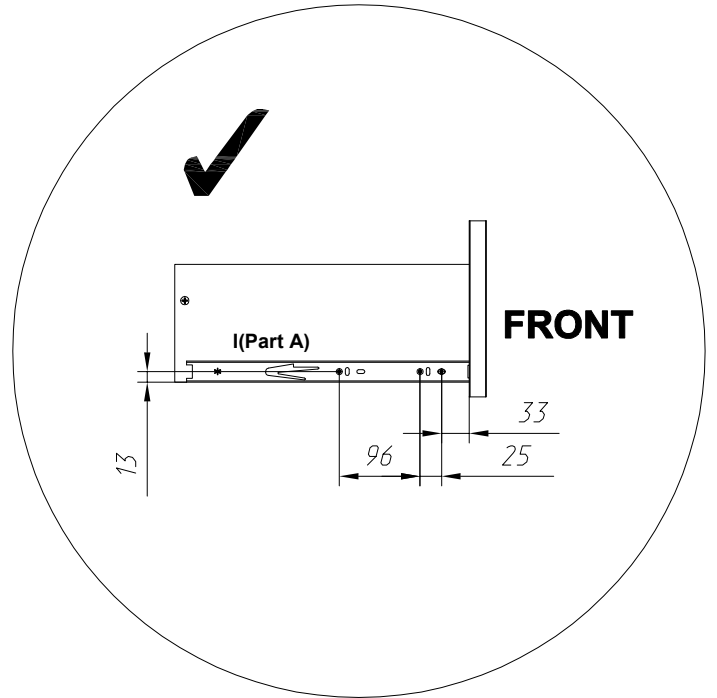

23

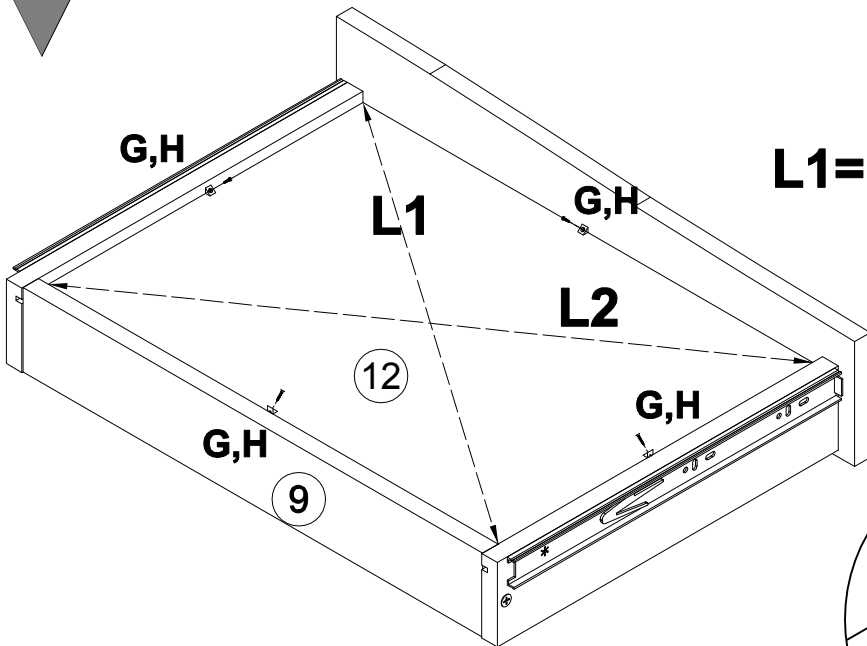

135021		H	3x20
x4		x4	

